

Powerline 20 & 30

User Manual for PL Series Saltwater & Mineral Chlorinators



Powerline
by **HAYWARD**™
www.hayward-pool.com.au



**FOR SERVICE CALL
1300 POOLS1**

Contents

Warranty Terms	2
Introducing the PL Series	4
How it Works	5
Installation Guide	6
Initial Pool Balance	10
Front Panel & Operational Buttons	11
Menu System	12
Timer Menu	13
Chlorine Output Menu	15
Operation Following a Power Failure	16
Status Indicator, Warnings and Safety Shutdowns	17
Troubleshooting	18
Maintenance	19
Cell Cleaning	20

IMPORTANT

If the power cord is damaged the unit must be returned to Hayward for repair.

Always read the instructions and warnings on chemical containers before using chemicals.

Serial Number.....

Date of Installation.....

Installed by.....

Standard Warranty – Professional Sales and Installation – Effective July 1st, 2016

To the original purchaser only, on-site warranty is provided at the discretion of Hayward Pool Products (Australia) Pty Ltd and is available according to the following schedule and is subject to our standard warranty conditions.

Product Description	Sold and installed by an approved installer	
	Parts	In-field Labour
Powerline Control Box, Dosing System & Electrolytic Cell ^{*2}	3 Years	1 Year
Spare Parts ^{*3}	1 Year	1 Year
Eligibility to claim		
To be eligible to claim warranty support available to the original purchaser, prior to repairs being undertaken you must: a. Provide proof of purchase and installation by an Authorised/ Qualified Professional Dealer. b. Where warranty claim is made, supply and installation must be completed by an Authorised/ Qualified Professional Dealer or Builder, warranty certificate must be completed including installer's full business details, copy of original receipt and signature of approved partner's representative. Where proof of professional installation is not provided, warranty is limited to 12 months- parts only. c. Where proof of purchase cannot be provided you will not be entitled to warranty support. d. Any item that is hard wired to a power supply cannot be serviced on site. In this case contact Hayward Pool Products (Australia), an Authorised Service Agent or place of purchase for instruction.		
Conditions		
1. On-site support will only be provided for installations located within 10km of the Authorised Service Agent in the metropolitan areas of Melbourne, Sydney, Brisbane and Perth, or within 20km of an Authorised Service Agent in regional areas. For Installations outside the specified radius the customer may have to pay a travel fee. Warranty does not cover damages resulting from incorrect installations, improper storage, improper operation, water chemistry or freezing. 2. To claim warranty a history of water balance test records must be provided to show compliant water balance has been maintained for the product. 3. Parts including mechanical seals, multiport valves, elements, pressure gauges, grids, cartridges, bearings, shoes, wings and drive tracks are considered spare parts and therefore qualify for 1 year manufacturer's defect warranty. Warranty commences from date of original purchase and is not extended in the event of a repair or replacement. Squeeze tubes on peristaltic pumps need to be replaced every 6 months		

Warranty- Standard Conditions

Hayward Pool Products (Australia) Pty Ltd (ACN 083 413 414) ("Hayward Pool Products (Australia)") distributes Hayward Pool Products in Australia and New Zealand and provides the following warranties:

STATUTORY RIGHTS

1. The benefits to the consumer under this warranty are in addition to other rights and remedies of the consumer under the laws in relation to the goods and services to which the warranty relates; and
2. Our goods come with guarantees that cannot be excluded under the Australian Consumer Law. You are entitled to a replacement or refund for a major failure and compensation for any other reasonably foreseeable loss or damage. You are also entitled to have the goods repaired or replaced if the goods fail to be of acceptable quality and the failure does not amount to a major failure.

LIMITED WARRANTY

Hayward Pool Products (Australia) warrants that its products are free from defects in materials and manufacture for 12 months from date of supply by Hayward Pool Products (Australia) plus 90 days to allow for installation and supply (unless otherwise specified). Hayward Pool Products (Australia) will at its discretion, except in the circumstances described below, either replace or repair any product proven to be defective during the warranty period for either materials or manufacture or alternatively pay the cost of repair or replacement within 90 days of the receipt of the defective product, barring unforeseen delays. This warranty is personal to the original purchaser and does not pass to any subsequent purchaser(s).

To the extent permitted by law, Hayward Pool Products (Australia) will not be liable for products which fail or become

defective during the warranty period as a result of freezing, accident, negligence, improper installation, water chemistry, misuse or lack of care.

To the extent permitted by law, except as set out in this Warranty, Hayward Pool Products (Australia) excludes all statutory or implied conditions and warranties and any other liability it may have to the Customer (including liability for indirect or consequential loss) that may arise under statute or at law including without limitation for breach of contract, in tort (including negligence) or under any other cause of action.

To the extent permitted by law, except as set out in this Warranty, Hayward Pool Products (Australia) limits its liability under any condition or warranty which cannot be legally excluded in relation to the supply of Goods and Services to:

1. Replacing the Goods or supplying equivalent Goods or Services again;
2. Repairing the Goods;
3. Paying the cost of replacing the Goods or of supplying equivalent Goods or Services again; or
4. Paying the costs of repairing the Goods.

PRODUCTS REQUIRING QUALIFIED INSTALLATION

Some products due to their technical nature are only intended for sale by retail shops where local sales and technical support can be provided or as a part of a new Pool Installation. Where installation has not been carried out in accordance with this requirement, warranty labour and support will be the sole responsibility of the reseller supplying the product. Warranty claims for such products will be limited to replacement of parts only, with faulty goods being returned to place of purchase for processing.

The following products as well as those that may be designated by Hayward Pool Products (Australia) from time to time, are not specifically intended for owner installation and are deemed to be technical products:-

- Heaters - All;
- Hayward Dosing and Chemistry Control;
- Hayward Pool and Spa Controls;
- Puresilk and Powerline Dosing and Chemistry Control;

Claims made for warranty, labour or infield support will not be accepted by Hayward Pool Products unless evidence is provided that installation has been completed in accordance with standard warranty conditions. Please refer to specific program document for details.

HEATING PRODUCTS

Please note that warranty claims for Heaters are handled directly by Hayward Pool Products (Australia) and are not authorised for over the counter exchanges. These items are site specific and involve local conditions such as placement, installation, water chemistry, fuel supply and electricity. Each unit needs to be evaluated on the site utilising Hayward Pool Products (Australia)'s authorised service network. Hayward Pool Products (Australia) will not be responsible for additional costs incurred where a heater has been installed at a location situated further than 20km from an authorised service outlet. Advice must be sought in writing from Hayward Pool Products (Australia) to determine appropriate service procedure on a case by case basis.

EXCLUSION FOR WEARING PARTS

This warranty does not extend to wearing parts, in particular the squeeze tubes fitted in peristaltic dosing pumps. Squeeze tubes should be replaced every six months by a suitably qualified technician. Hayward is not liable for any failure of its products or other damage caused by failure of a squeeze tube that has been used for more than six months.

Hayward Pool Products (Australia) Pty Ltd

ABN 66 083 413 414

PO Box 4384, Dandenong South, VIC, 3164

Melbourne, Sydney, Brisbane, Perth

T (+61) 3 9792 2325 or 1300 POOLS1

F (+61) 3 9794 9945 or 1300 POOLS2

email: sales@hayward-pool.com.au web: www.hayward-pool.com.au

Introducing the PL Series®



What's in the box?

The image above shows the main parts of the PL Series system (clockwise from top left):

- PL Series® Cell and Cell Cable
- PL Series® Power Supply and Mains Cable

Also included in the box, but not illustrated:

- User Manual
- Mounting hardware (raw plugs, screws and paper template)
- 40/50 bushes

How it works:

A salt/mineral chlorinator works by putting a dc current through an electrolytic cell in a flow of salted water. Salt/minerals are made up of sodium/magnesium and chloride ions. Electrolysis of these salts produces chlorine gas, which dissolves almost instantly to form free chlorine in the water. This free chlorine is a highly effective sanitiser for your pool.

The PL Series[®] constantly adds a dose of chlorine to the water over the operating period of the system. The amount of chlorine added depends upon the cell output and the running time.

Generally, a salt water / mineral pool is run for around 8 hours per day in summer and 2 to 4 hours per day in winter. The summer operating periods are usually in the early morning and later evening. This allows a chlorine residual to build up for pool use during the day.

The filter system should always be running when the pool is being used.

Optional pH Control

When chlorine is added to water the pH always changes – this is because chlorine is not a neutral chemical. The pH will slowly rise as chlorine is produced in a salt/mineral water system. A rise in pH greatly reduces the effectiveness of the chlorine as a sanitiser, so it is important to ensure that the pH remains in the correct range.

The pH of the water can be lowered by the addition of acid – and if your PL Series[®] has the optional pH control, this can be done automatically. The PL Series[®] uses a sophisticated algorithm to calculate how much chlorine has been produced by the cell, and how much acid needs to be dosed to correct the resultant pH rise.

The algorithm can be adjusted if installed on a concrete/plaster pool. When adjustments are made it should be in small values with the pool then monitored for effectiveness.

Note: while the algorithmic pH control is effective it does not measure pH. pH measurement and checking must be done manually to make sure the pH is correct.

Installation Guide

Installation Diagrams

For most installations, please refer to the installation diagram on page 8.
If your PL Series® has the optional pH control, refer to the installation diagram on page 9.

Choosing a good location

The PL Series® is manufactured from weather resistant materials and is designed for operation in full sun and rain. However, your PL Series® will benefit if it is protected from the weather.

Choose a well ventilated area to allow for efficient cooling. Installing the unit in a hot and closed shed or box may lead to overheating and activate the internal protective thermal cut-out.

The PL Series® Power Supply should not be mounted in areas where chemicals are stored (eg acid and chlorine) as vapours from these chemicals are corrosive and may damage the electronic controls within the unit.

Insect intrusion (particularly ants) can cause problems with all equipment. Ensure that the pool equipment area is kept free of insects as much as possible. Insect intrusion is not covered under the warranty.

Installing the PL Series® Power Supply

Locate the PL Series® Power Supply close to the Cell/Housing and filtration pump so that both may be connected easily.

Connect the PL Series® Power Supply to the mains power outlet of the pool area and make sure this outlet meets all applicable Australian Standard at the time of installation.

Mount the PL Series® Power Supply at least 1.5m above the ground and at least 3m from the pool water. A mounting template is printed on the last page of the manual.

The PUMP socket outlet in the base of the PL Series® Power Supply is dedicated to the filtration pump only. Do not use a double adaptor to connect another pump as this will overload the system and void warranty.

Installing the PL Series® Cell

The PL Series® cell housing assembly should be plumbed into the pool return line after all other accessories (and prior to any heating take-offs).

Remember that the cell will need to be removed from its housing periodically for cleaning – do not place it where its removal will be obstructed.

Note any water flow direction on the cell housing and insure the cell housing is installed so that water will flow in this direction.

Connect the cell cable to the cell connector on the base of the PL Series® Power Supply. Ensure that all 3 connections (2 for cell power and 1 for gas sensing) are colour matched and not loose.

pH Control (optional)

Units with pH control have an injection fitting and a peristaltic pump which must be installed. Refer to the installation diagram on page 9 for details. Mount the peristaltic pump unit adjacent to the PL Series® Power Supply, as it is hard-wired to this power supply.

Cut a length of tubing that will reach from the base of the peristaltic pump to the injection fitting. Connect one end of the tubing to the outlet side of the peristaltic pump (the direction of flow is indicated by an arrow on the front cover of the pump.) Connect the other end of the tube to the injection point.

Cut another length of tubing that will reach from the base of the peristaltic pump to the base of the acid drum. Position the acid drum in a safe and secure location, preferably about 2 metres from the PL Series®.

Connect the one end of this tube to the inlet side of the peristaltic pump (the direction of flow is indicated by an arrow on the front cover of the peristaltic pump.)

Drill an 8mm hole in the lid of the acid drum and pass the tubing through the hole in the drum lid. Place a sinker on to the end of the tubing that will be in the drum and then attach the drum filter. Note that the drum filter incorporates a non-return valve to prevent back-flow into the chemical drum.

Before placing the tubing into the drum, measure the tubing against the outside of the drum and wrap several turns of PVC tape around the tubing above the drum lid so that the drum filter will be 10-15mm above the bottom of the drum. Lower the drum filter and sinker into the drum and screw on the lid.

Pool Light Outlet

Your PL Series® has a light power outlet in the base – this can be used to run up to a 150W pool light power supply. This outlet is timed, allowing pool lights to be set to come on and turn off automatically.

Powerline Installation Diagram

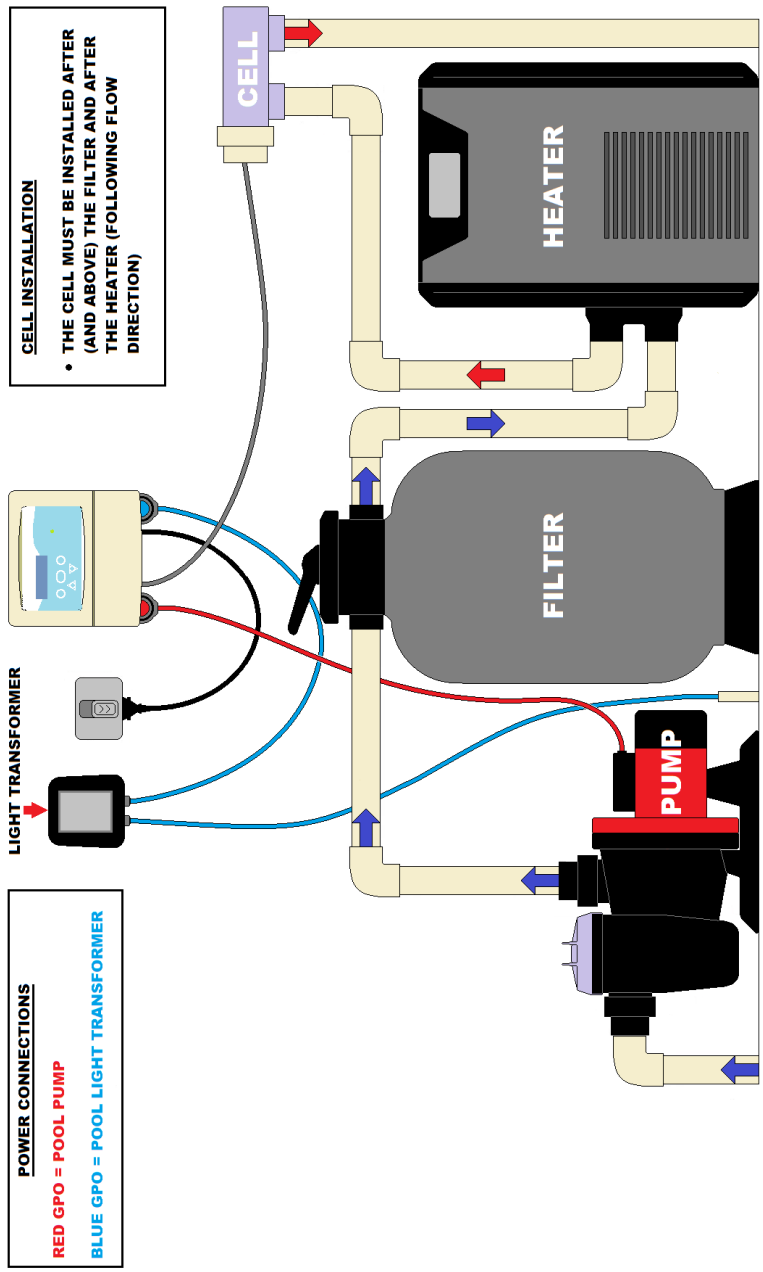

Powerline Installation with pH Acid Doser

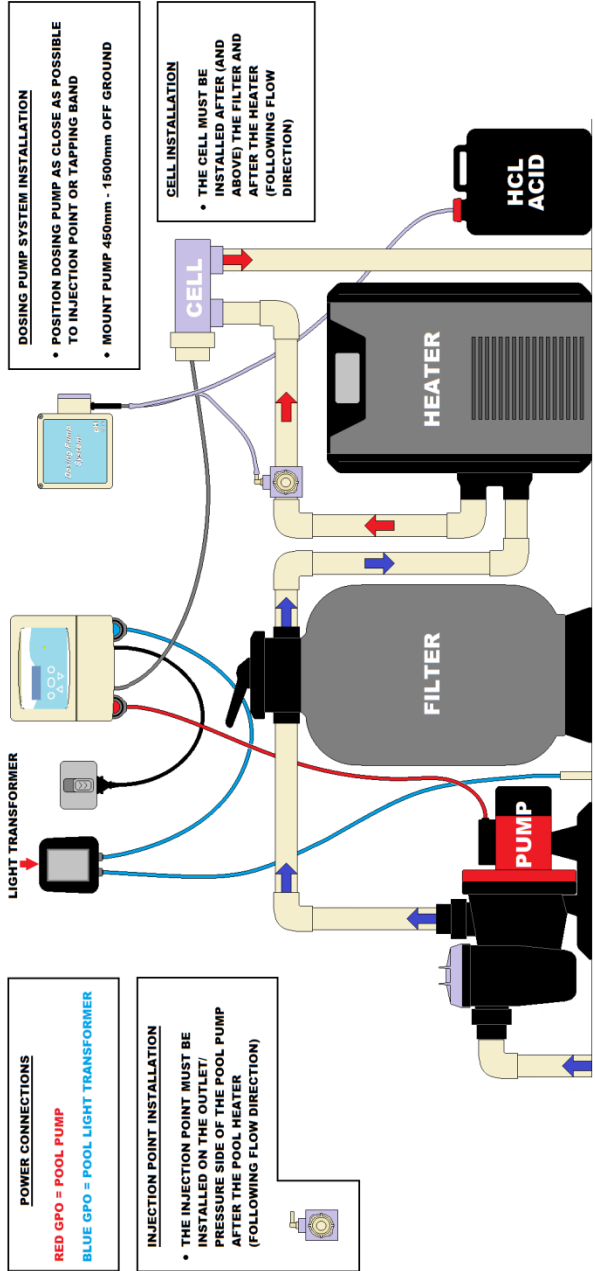

Initial pool balance

Before you begin using the Chlorinator, make sure your pool water is balanced as follows:

Salt and Minerals – only add salt/minerals after checking the levels

There should be between 3000 and 5000ppm of TDS in the pool ideally 4000ppm.

This is achieved by adding 4kg of salt for every 1000 litres (1m³) of pool volume. Note that this amount of salt will take time to dissolve.

Minerals: the conductivity of minerals is different to pure salt. All TDS testers are calibrated for sodium chloride salt. You will need less weight of minerals to achieve an equivalent TDS to salt – follow the mineral instructions.

Note: keep salt/minerals below 7500ppm to avoid overloading the cell and causing shutdown. Only add after checking the level.

Chlorine - If it is a new installation, add enough chlorine (liquid or granular) to achieve a reading of 3ppm on an appropriate test kit.

Stabiliser - If the pool is outdoors, it is vital that stabiliser (also known as cyanurate and cyanuric acid) be added and maintained at 50ppm. This compound reduces chlorine destruction due to sunlight. However, too much stabiliser will reduce the effectiveness of chlorine and can result in poor quality water so ensure stabiliser does not exceed 80ppm.

pH - For chlorine to be effective, the pH must be within a certain range. This is usually between 6.8 (fibreglass/liner pools) or 7.2 (concrete/plaster) and 7.8.

Adjust pH down with acid – powder, liquid sulphuric or liquid hydrochloric. Be very careful with acid as it can be harmful and corrosive.

Minerals: the magnesium in mineral salts can form a soft scale on the cell even though it is reversing polarity. This is minimised by keeping the pH at the lower range for your pool type. The use of hydrochloric acid is recommended for magnesium mineral systems.

Total Alkalinity (TA) - Total alkalinity is also known as carbonate hardness or TA for short. The recommended level is between 80 and 120ppm.

TA is related to pH in that it stops the pH from varying quickly with small additions of acidic or alkaline chemicals. When the TA is low it is almost impossible to control the pH. To raise the TA, buffer (sodium bicarbonate) is added. This must be done slowly as buffer will also cause the pH to rise. As an approximate rule every increase of 20ppm of TA will also cause a 0.1 rise in pH. Once buffer is added it should be left to mix in the pool for a few hours before reducing the pH.

Phosphates and Nitrates - Phosphate and ammonia nitrogen will make your garden green – and they will do the same thing to your pool. Check for phosphates and add phosphate remover if necessary. Don't let fertiliser get into your pool! Ammonia nitrogen has a very high chlorine demand. Phosphates are also in some cleaning products – check the label if using around your pool.

The PL Series Front Panel

PL Series® Display

The PL Series® uses a two line LCD display to provide the user with information.



10:15 CELL OFF
AutoOFF→ON@17:00

The first line of the display shows the current time and the cell status and output. In the example above the time is 10.15am and the Cell is “OFF”. If the Cell is on, the output of the Cell will be displayed. If the output of the Cell has been set at lower than 100%, “CELL OFF” will be displayed intermittently even while the unit is running as the Cell regulates output. (See Chlorine Output Menu on page 16 for more details)

The second line of the display shows the automatic timer status. In the example above, the automatic timer status is “OFF” and the display is telling you that the PL Series® will turn on again at 17:00 (5pm).

Note that the PL Series® displays the time using a 24 hour clock.

PL Series Operational Buttons

Your PL Series® has 5 buttons that allow you to control the various functions available via the PL Series® Menu system.

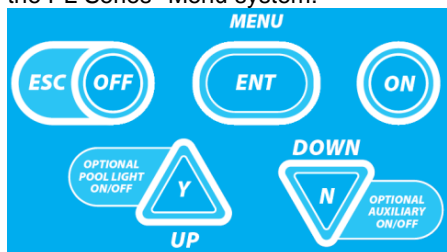

Each button is labelled with its primary function either on the button itself, or adjacent to it. Secondary functions are labelled within a curved white outline next to the relevant button.

The buttons are backlit to show which are active at any given time, although the ESC/OFF button is always available to take

ON Button

Turn the System On Manually

Press the ON button once to switch the PL Series® and the pool pump on manually. The PL Series® will default back to AUTO and turn itself off automatically at the end of the next programmed FILTER CYCLE (and this time will be displayed on the LCD).

Increasing Manual Run-time in Hourly Increments

Press the ON button repeatedly (or hold the button down) to increase the manual run time in hourly increments. The run time is displayed on the LCD. When the desired run time has been reached, press the ENT button to confirm your selection and the system will commence operation.

ESC/OFF Button

Turn the System Off Manually

If the PL Series® and pool pump are running, pressing this button will turn them off manually. The PL Series® will automatically turn on again at the start of the next FILTER CYCLE (and this will be displayed on the LCD).

Return to Home Screen

If you have unintentionally accessed a PL Series® Menu that you don't actually require, pressing the ESC/OFF button allows you to return to the home screen at any time.

ENT Button

Use this button to enter the PL Series® Menu system and to access the various options in each Menu. Use the Y/UP and N/DOWN buttons to scroll through menu options and when your desired menu option is displayed on the LCD, press ENT to access that option.

Y/UP Button and Optional Pool Light

If you have accessed the PL Series® Menu by pressing the ENT button, press the Y/UP button to scroll upwards through the various menu options. Some menu options will prompt a yes or no answer. If you wish to answer "yes", press the Y/UP button.

If your PL Series® also controls your pool lighting (optional), you can turn the lights on or off manually by pressing the Y/UP button. For multi-coloured lights, hold the Y/UP button down to cycle through the various colours and release once the desired colour is reached.

Navigating the PL Series Menu System

There are two aspects to the general PL Series® Menu system – the Timer Menu and the Chlorine Output Menu.

Access the PL Series® Menu system by pressing the ENT button and following the prompts on the LCD. If you find you have ended up in a part of the Menu system unintentionally, you can return to the Home Screen by pressing the ESC/OFF button at any time.

Use the Y/UP and N/DOWN buttons to scroll through the various menu options until the desired option is displayed on the LCD. Use the ENT button to confirm that you wish to select that option.

Once accessed, use the Y/UP and N/DOWN buttons to adjust operational settings up or down – and confirm adjustments by pressing ENT. To cancel any adjustments, simply press ESC/OFF to return to the Home Screen.

Timer Menu

Setting the time

Once you have installed your PL Series® and turned it on, you will need to set the correct time on the PL Series' 24 hour clock.

First, access the Menu System by pressing the ENT button. The LCD will display the word TIMER MENU. Select this by pressing the ENT button once more.

Line 2 on the LCD will now read SET TIME HOURS. Press ENT to select this option and then use the Y/UP and N/DOWN buttons- to adjust the hours on the LCD. Confirm the correct hours value by pressing ENT again.

The LCD will now show SET TIME MINUTES. Adjust the minutes using the Y/UP and N/DOWN buttons. When complete, press ENT to return to normal operation.

Filter Cycles Menu

Your PL Series® has two filter cycles pre-programmed as factory defaults as follows:

Filter Cycle 1:	ON at 7:00 (7am)	OFF at 11:00 (11am)
Filter Cycle 2:	ON at 18:00 (6pm)	OFF at 22:00 (10pm)

You can change the start and finish times of each filter cycle to meet your sanitiser requirements and to suit your lifestyle.

To adjust filter cycle start and finish times, press ENT to access the PL Series® Menu system. Press ENT again to select the TIMER menu and then scroll down using the N/DOWN button until ADJUST CYCLES is displayed on the LCD.

Select this option by pressing ENT and the LCD will show the start (ON) time of the filter cycle being adjusted. Use the Y/UP and N/DOWN buttons to adjust the start time. Press ENT to confirm your selection and then the LCD will show the end (OFF) time for that filter cycle. Adjust the OFF time in the same way as the ON time and press ENT to confirm.

After ON and OFF times for the first filter cycle have been adjusted, the ON time for the second filter cycle is shown on the LCD. This can be adjusted in the same way, or if you do not wish to make any changes, simply press ENT to confirm the time shown on the LCD. Follow the same process to either adjust or confirm the OFF time for the second filter cycle, and once this has been confirmed the LCD will display the home screen.

Running Times

We recommend your system be operated for ***at least 8 hours per day and always run the system when using the pool.*** The amount of chlorine being added to the pool each day is determined by the cell size, the chlorine output settings (See Chlorine Output Menu below) and the number of hours that the PL Series® is operated. As sunlight destroys chlorine, it is recommended that the PL Series® be run mostly in the evening.

Chlorine is added for sanitation but the filter is needed to remove pollutant particles (dust, sand etc) and keep the water looking good. The filter must operate for a reasonable number of hours per day to remove pollutants.

In very hot weather and/or with large bather loads, the pool may need to run for even longer and if necessary, extra chlorine should also be added manually. If there are adverse local conditions – such as windborne dust and debris - the chlorine demand will be higher than normal and you will likely need to operate the system for longer periods to adequately filter the water.

Light Timer Menu

You can use your PL Series® to turn your pool or garden lighting on and off automatically, you can set the ON and OFF times using the light timer menu.

Press ENT to access the PL Series® Menu system. Press ENT again to select the TIMER menu and then scroll down using the N/DOWN button until LIGHT MENU is displayed on the LCD.

Line 2 on the LCD will now read “AUTO? Y/N”. To enable automatic light operation press the Y/UP-button. Line2 will read “Auto ON” for short period before displaying “ON hh:mm”.

Adjust the ON time using the Y/UP and N/DOWN-buttons and confirm by pressing ENT. The LCD will now prompt you to set the OFF-time, which is accomplished using the Y/UP and N/DOWN-buttons as before. Press ENT-to confirm the new OFF-time and the LCD will return to the home screen.

To disable automatic light operation, access the LIGHT menu in the way described above and when asked “AUTO? Y/N” - press the N/DOWN button. Line 2 will read “Auto OFF” for short period then the system will return to normal operation and the light can only be operated manually (see below for how to do this).

Manual Light Operation

If the PL Series® is turned on, the light can be turned on or off manually by pressing the Y/UP-button.

If you have multi-coloured LED lights that cycle through different colours and requiring a power pulse to change effects, you can hold down the Y/UP-button to cycle through the options and release when the desired colour or effect is achieved.

Controlling the Chlorine Residual

There are two ways of controlling the amount of chlorine entering the pool – by altering the running times and by reducing the PL Series[®] Output. If the pool chlorine residual tests high you can reduce the operating time and/or decrease the Output. If the chlorine residual tests low and the output is already at maximum you will need to increase the operating time and/or add supplementary chlorine.

PL Series[®] Output Control

The LCD display usually shows the amount of chlorine being produced by the Cell as a percentage of its maximum.

However, this is not the same as the PL Series[®] Output. The Output Control turns the Cell ON/OFF over a short period of time. The Output setting determines how long the ON time is – for example if the Output setting is 60% the Cell will be ON for 60% of the period and OFF for 40% of the period. This is why the Cell will turn ON/OFF if the PL Series[®] Output is below 100%.

Chlorine Output Menu

To adjust the chlorine output on your PL Series, press ENT to access the PL Series[®] Menu system. Scroll down using the N/DOWN button until CHLORINE OUTPUT is displayed. Press ENT again to select this menu and then use the Y/UP and N/DOWN buttons to adjust the output level. Confirm the adjusted settings by pressing ENT once more.

Superchlorination

When bathers enter a pool there is a reaction between nitrogen/ammonia compounds from the bathers and the chlorine in the pool. These reactions form chloramines (also called combined chlorine) which are responsible for the “chlorine” odour and for some minor irritations.

These compounds can be broken down by adding free chlorine to a level above 5ppm by the addition of a shock dose of chlorine – also known as superchlorination.

Levels of chlorine immediately adjacent to the PL Series[®] Cell anodes far exceed 5ppm and so a lot of chloramines are destroyed as water passes the Cell.

If the chloramine levels still become high, simply add a shock dose of chlorine or run the PL Series[®] for a long period overnight.

Operation Following a Power Failure

The PL Series[®] unit comes with a timer function built into the operating software. The timer is a 24-hour type with quartz-crystal control. This Timer is backed-up by a Real-Time Clock (RTC) similar to those found in computers.

During a power failure the PL Series[®] will keep time and maintain AutoMode functions.

If a Filter Cycle is active when power is returned the pump will be turned ON within 1 minute. The PL Series[®] will keep all its settings and will not need to be re-programmed.

The PL Series[®] is ideal for use in systems where repeated power cuts occur, such as off-peak power circuits and Queensland's Tarriff33 system.

PL Series Status Indicator, Warnings and Safety Shutdowns

There is a STATUS indicator on the front panel that simply shows green (OK) and red (WARNING). The reason for any WARNING will be written on the LCD display. Possible warnings are explained below.

Low Water Temperature & Salinity



Low water temperature and lower than recommended salt/mineral levels can both cause low conductivity of the water to be detected.

The PL Series® will, however, continue to function and will display this without a red warning indication. Simply check the salt level and make sure it is well above 3000ppm (ideally around 4000ppm).

Check the temperature of the water, and if it is lower than 20°C, you may wish to adjust the Water Temperature setting using Advanced Settings Menu (information on Advanced Settings available via www.hayward-pool.com.au or by calling Hayward Service on 1300POOLS1.

Gas Detection & Dry-Run Pump Shutdown

This is an important safety feature of the PL Series® as a build-up of chlorine gas can be dangerous.



The display above left shows the Cell being turned OFF after chlorine gas is detected for approximately 10 seconds. If gas is still detected after approximately 2 minutes the pump will also be turned OFF – and the display will read as shown above right.

To re-start the pump, simply press the ON-button (as instructed by the display). This will reset the warnings and allow the pump to run (for a maximum of 3 minutes if gas is still detected).

High Salt

Too much salt/mineral in the water results in high conductivity and the PL Series® Cell may overheat. The PL Series® will shut down to prevent this.



If the above warning is present, the PL Series® will have shut down to avoid an overload (mandated by electrical standards).

Check the salinity/TDS and water temperature. Salinity/TDS should be kept below 7,500ppm, and ideally will be above 3000ppm.

The PL Series® is not designed for operation in seawater or brine.

Trouble-shooting

Before requesting service, you may wish to run through the check list below but feel free to call Hayward Service on 1300POOLS1 or log a service call via our website – www.hayward-pool.com.au.

If there appears to be low or no Chlorine Residual:

1. Check stabiliser level is 40ppm – 60ppm. Add if necessary and wait for it to dissolve.
2. Have you added any chemical additives recently?
3. Check pool for phosphates and remove if necessary
4. Is the unit turned on and operating the filter pump?
5. Are the operating hours sufficient?
6. Is the Output set to 100%?
7. When running is the Cell ON? Is it reading 100?
8. Is there enough salt in the water? (4000ppm)
9. Is the temperature of the water low?
10. Is the Cell scaled heavily?

If the Cell is ON but not reading 100, check the Temperature Compensation setting in the WATER TEMP MENU (located in Advanced Settings – see www.hayward-pool.com.au for Advanced Settings Manual). Also check the pool salinity is within correct range.

If the unit is not running at all **check the fuse** in the lower section of the unit.

Danger: ensure to remove the unit's power chord from the power point (GPO) before removing the fuse.

Maintenance

Like all equipment the PL Series® will look better and last longer if it is maintained and operated in accordance with these instructions.

The PL Series® Power Supply

The Power Supply has been design for operation in full sun and weather. However, it will benefit from being under cover. There is little maintenance required however – some Do's and Don'ts –

Don't:

- Install it in a small sealed enclosure (so it does not overheat)
- Install it in a very hot unventilated shed (so it does not overheat)
- Allow insects to nest in the unit (because they will prevent it from functioning)
- Install chemical drums under or close to the unit (to prevent corrosion)
- Forget about the unit once installed – it should be checked regularly to ensure that it is working for you

Do:

- Install it as per the instructions
- Check it regularly
- Make sure the pool balance is checked regularly

The PL Series® Cell

The Cell does not have an unlimited life because its anodes (active electrodes) will wear away slowly as it produces chlorine.

Scale forms on the PL Series® Cell cathodes (negative electrodes). Scale is a combination of calcium/magnesium and other mineral salts (usually carbonates). The rate of scale build-up is determined by the amount of use, the pH/calcium hardness/TA and the temperature of the pool water. Generally concrete and plaster pools will scale much faster than fibreglass pools due to higher calcium levels in the water caused by leaching of minerals from the pool surface.

The Cell is manufactured from extremely expensive materials so if it fails early due to lack of maintenance, the pool operating cost will not be as economical as it could have been.

Note that bore water generally contains far more minerals than scheme water. If bore water is used it is likely that faster Cell scaling will be seen.

Cell Cleaning

The PL Series[®] Cell is self-cleaning, however, some conditions such as very hard water can cause the cell to become scaled over time.

Do not remove the cell straps (holding the electrodes in place) when cleaning.

The PL Series[®] Cell uses an electronic means (polarity reversal) to remove scale from its cathodes. This system works very well in most pools unless there is extreme hardness and/or mineral levels. Even in the extreme cases where scaling does occur the rate at which it occurs is far slower than for normal Cells.

Minerals: the magnesium in mineral salts can form a soft scale on the cell even though it is reversing polarity. This is minimised by keeping the pH at the lower range for your pool type. Soft mineral scale can generally be hosed off with a strong jet of water.

If scale has become thick enough to nearly bridge between the Cell electrodes, it is time to clean the Cell. Cells can be cleaned in a solution of hydrochloric acid.

Please read the warnings and instructions on the acid container.

To make the acid solution, add 1 part hydrochloric acid to 4 parts water in a suitable container. This solution can be used a number of times so a re-useable container with a lid can be used, but make sure it is stored safely.

Alternatively a commercial Cell Cleaning solution can be used according to the manufacturer's instructions.

The PL Series[®] unit should be turned off so that any AutoMode functions cannot turn it back on until after the Cell is clean and back in its housing.

Remove the Cell from its housing and immerse in the acid solution. Note that it may foam up and overflow the sides of the container – so take care!

The Cell should not take longer than a few minutes to clean. It may also be possible to remove some or most of the scale with a jet of water.

Never use a stiff brush or hard implement to clean the cell because this will damage the coating.

