

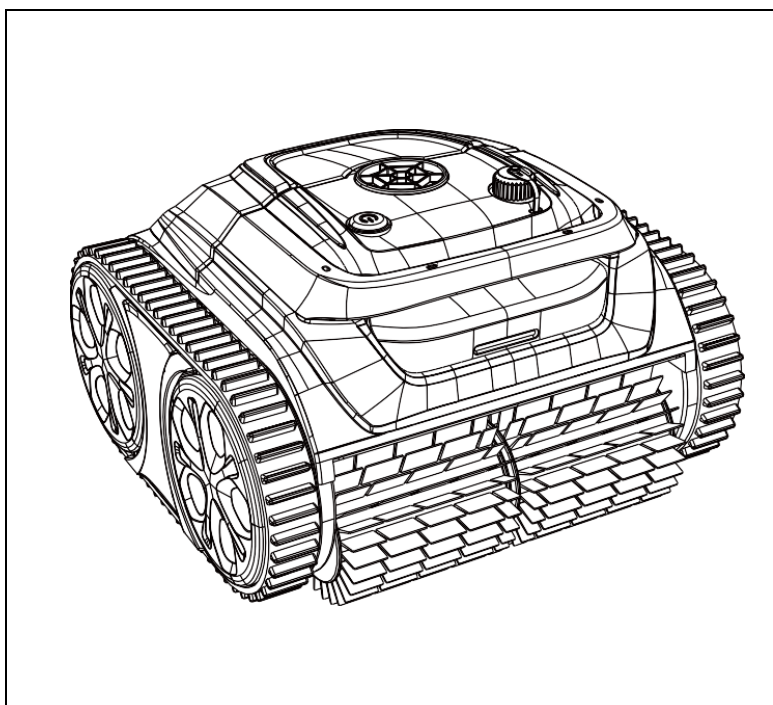

# HAYWARD®

## iPowerShark

Cordless Robotic Pool Cleaner



### Contents

Safety Instructions.....	2
Packing list.....	3
Specifications.....	4
Product overview.....	5
Charging.....	6
Mobile App connection.....	7
Operation.....	8
Cleaning basket.....	9
Floating blocks.....	10
Limited warranty.....	11
Maintenance.....	12
Troubleshooting.....	13
Parts list.....	14



## OWNER' S MANUAL

# IMPORTANT SAFETY INSTRUCTIONS

Basic safety precautions should always be followed when using this appliance, including the following: failure to follow instructions can cause death or severe injury and damage to the property. This Owner's Manual contains specific precautions and symbols to identify safety-related information. You will find DANGER, CAUTION, WARNING and NOTICE symbols which require special attention. Please read them carefully and follow these precautions as indicated! They will explain how to avoid hazards that may endanger you or people using this cleaner.



## READ AND FOLLOW ALL INSTRUCTIONS

### NOTICE:

- This document should be given to the owner of the swimming pool and must be kept by the owner in a safe place.
- During the operation of the machine underwater, slight "lifting" of the machine may occasionally occur, it is a normal operation procedure of the machine, not a failure.
- The maximum operating depth of this cleaner 3 meters (10 ft).
- Operating water temperature: 5°C (41°F) to 35°C (95°F).
- The battery must be removed from the robot before it is scrapped. Follow local council E-waste disposal regulations.
- This robot contains a battery that are only to be removed by skilled person.
- For details regarding battery disposal, refer to the section "Battery Disposal" in this manual.
- This robot is designed for underwater use only; it is not an all-purpose vacuum cleaner.
- Use only the original accessories delivered with this product.

 **DANGER:** Never insert body parts, clothing and other objects into the openings and moving parts of the robot.

 **DANGER:** The cleaner should be charged in 5°C - 35°C (41°F - 95°F) environment. When the battery is overheated, it shall be cooled before charging.

### WARNING:

- Children and pets should be supervised to ensure that they do not play with the cleaner.
- DO NOT ALLOW children and persons with reduced physical, sensory or mental capabilities to operate the cleaner unless they have been given supervision or instructions.
- Do not use this robot if any damage is detected.
- Replace damaged parts as soon as possible.
- Only authorized professionals can disassemble the cleaner
- DO NOT allow swimmers in pool while cleaner is operating.
- Store the cleaner in a cool and ventilated place, away from direct sunlight or any heat source.
- Use only the original charger provided with the unit. Avoid charging any other device with this charger. Improper use may result in overheating or corrosive liquid leakage from battery.
- The cleaner must be taken out from the swimming pool and turned off before charging and the charger and the cleaner must be placed indoors for charging.
- Dry the charging port after each leaning. Humidity in charging socket may cause an electric shock.
- The cleaner power supply unit must be plugged to an electrical circuit protected by a residual current device (RCD) having a rated residual operating current not exceeding 30 mA. Contact a qualified electrician if you cannot verify that the circuit is protected by a RCD.
- Do not charge the cleaner under fire or extremely hot conditions! Do not use or store the machine near heat sources.
- Disconnect the cleaner from the main supply and make sure it is powered OFF prior to servicing it such as cleaning the filter.
- This cleaner generates suction. Do not allow hair, body, and any loose parts of your clothing to make contact with the suction hole of the robot during its operation.
- DO NOT use this cleaner to pick up any toxic substance, flammable and combustible liquids such as gasoline, and in the presence of explosive / flammable fumes.
- Do not attempt to carry the cleaner by the cord of external adaptor, or pull the cord to disconnect it from the power source and charging base.

**CAUTION:**





- Use only genuine Hayward® replacement parts.
- REMOVE cleaner when performing backwash or during filter operation.
- DO NOT use the cleaner to remove large debris in new pools.
- REMOVE the cleaner before chemically shocking your pool. It is recommended to avoid the usage of the cleaner before 24/48h after pool-shocking.
- DO NOT use this robot without an intact filter in place.
- Wash and clean the filter basket after each use.
- DO NOT handle the robot charger adaptor while it is charging with wet limbs and without shoes.
- Do not operate the cleaner outside pool, otherwise it will affect the normal use of the cleaner.
- Charge the machine before the battery is completely exhausted. When the yellow light of the machine is on, please charge the machine in time.
- Do not charge the cleaner when the battery is full. Overcharging will reduce battery life.
- Charge the cleaner prior to being stored for a long time for over 6 months to maintain an optimal battery life.
- Keep the external adaptor disconnected from power when it is not in use.
- If you are planning on using the robot in a saltwater pool, make sure all salts are dissolved before placing it into the water.
- It is not recommended to use this robot with another automatic cleaner/cleaner simultaneously.

Above warnings and cautions are not intended to incorporate all possible instances for risks and / or severe injuries. Pool owners should always exercise extra caution and common sense when utilizing the product. Failure to operate the device as per the warnings can cause damage to the device or injury.

The cleaner is indented for use only in following water quality standards.

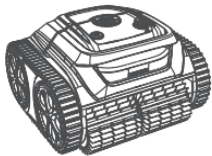
Chlorine	Max 4 mg/L
pH	7.0-7.8
Temperature	5-35°C
NaCl	Max 5000ppm

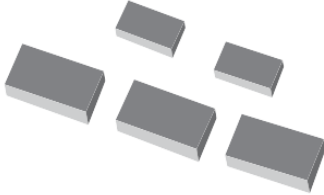
**PACKING LIST**

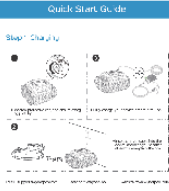
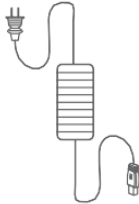
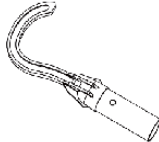
 <p>Device x 1</p>	 <p>Filter Basket x 1</p>	 <p>Adhesive Block x 5</p>	
 <p>Quick Start Guide</p>	 <p>Quick Guide x 1</p>	 <p>Charger x 1</p>	 <p>Hook x 1</p>

Use only Hayward® genuine replacement parts

## SPECIFICATIONS

Model	iPowerShark
Pool size	120m <sup>2</sup>
Depth	3m
Product dimensions (mm)	385 x 355 x 250
Weight	8.30Kg
Run time	180min
Charging time	150min
Battery	25.2V / 6.4Ah
Power	90W
Charger input	100-240V, 47-63Hz
Charger output	29.4V/ 3A
Filter Density	180um
Filtration rate	13m <sup>3</sup> /h
Moving speed	10m/min
Water resistance	IPX8
OTA updating	Available
App connection	Available
Operating pool water temperature	5°C - 35°C
Storage temperature	5°C - 35°C
Working cycle modes	A. Pool bottom & wall combination:160-180min B. Pool bottom:180-200min

PRODUCT OVERVIEW

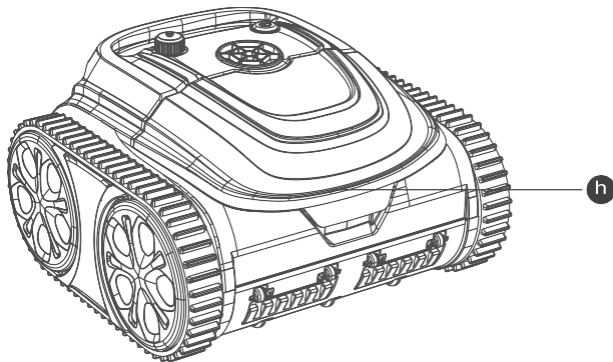
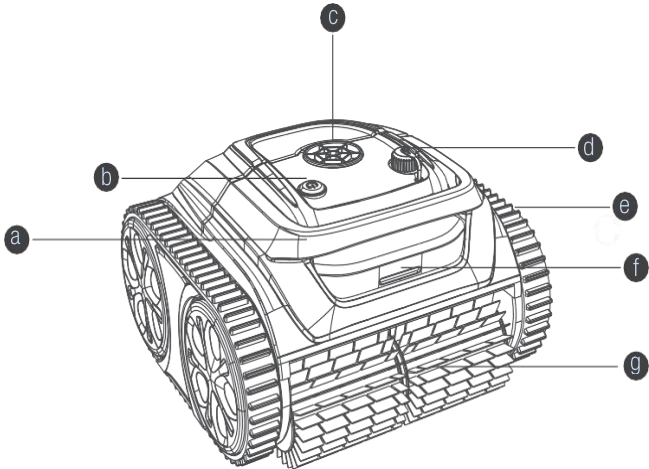

- a Handle: Remove and transport the device with it
- b On/off: Turn on/ turn off the device
- c Pump: Pump out water through the window
- d Charging port: Connect charger
- e Track: Support to climb walls and obstacles
- f LED Indicator: Different light colors to indicate status
- g Scrubbing Brush
- h Top cover handle
- i Filter basket
- j Sealed Motor assembly: Do not try to disassemble it without authorization

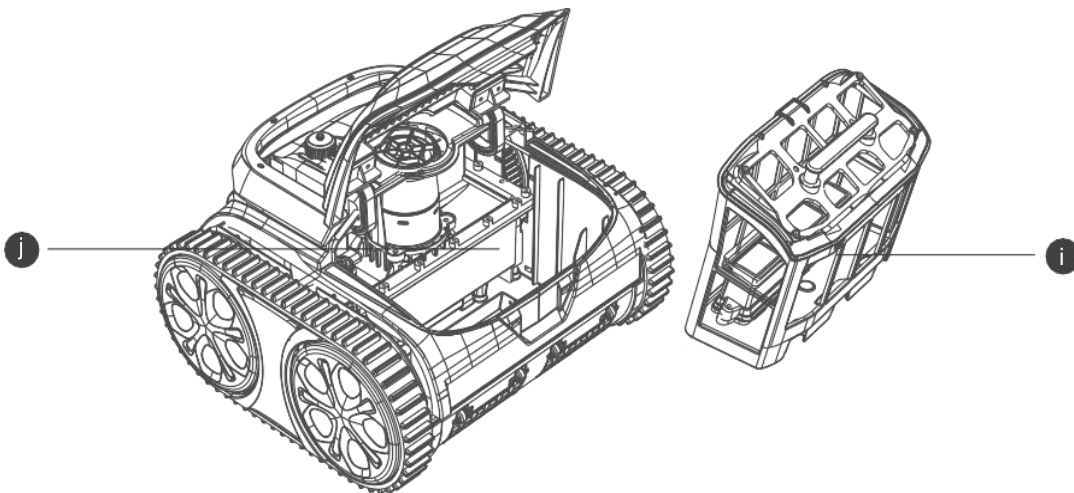

 Do not operate the device when the top cover or scrubbing brushes are broken. If there is any liquid leakage from the sealed part, stop charging or running the device.

## GET STARTED

### CHARGE YOUR NEW CLEANER

The device has a lithium-ion rechargeable battery, and you need to charge the battery before first use and when the battery is low. Connect your device to power outlet using the included cable and adapter.

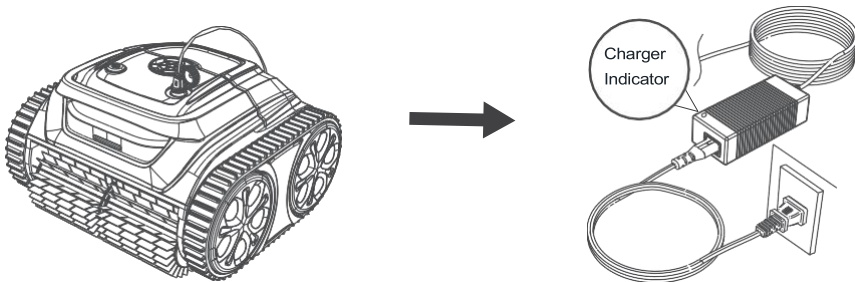

**⚠ WARNING:**

- Prior charging, make sure that the charging port is free of moisture and that the device is turned off.
- Avoid exposing the cleaner and adaptor to direct sunlight or water when charging.

**⚠ NOTICE:**

- When charging, it is important to make sure that the device is kept at least 3m away from the pool edge.

The adapter is equipped with an indicator to inform you of the charging status of the battery.

Color of the indicator	Indication
Red	Charging in progress
Green	Charging completed

### SETUP YOUR NEW CLEANER

You can turn the device by pressing the On/Off button. The LED indicator on the back will display solid blue when the device is on.

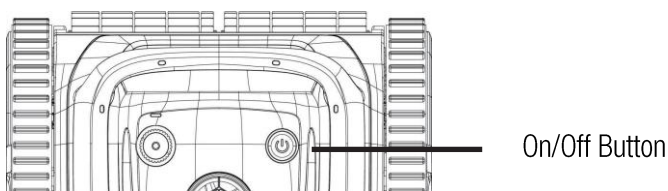

**Note:**

- When yellow light flashing, you should remove your device out of water and charge it.
- If Red light is on, you can find a solution from trouble shooting guide in this manual or call authorised service agent.

Below is the indication of LED lights, you may refer it to know the status of the device.

Blue    Purple    Yellow    Red

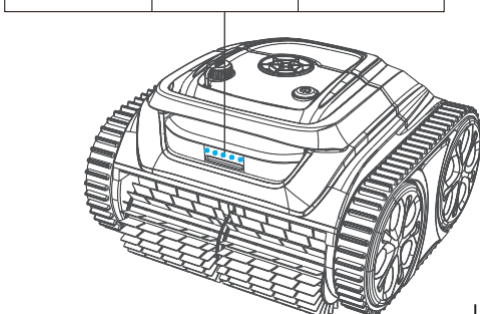

LED Color	Indication	Status
Blue	Solid	Power on
	Flashing	Under working
Purple	Solid	Connecting to App
Yellow	Flashing	Low battery or under self-parking in the pool
	Breathing (Bright to dim)	Self-parking completion
Red	Solid or flashing	Fault

Use only Hayward® genuine replacement parts

## CONNECT TO YOUR MOBILE APP

You can download the Hayward iPowerShark App to your smart phone by scanning below QR code.



**A** SCAN ME

iOS	Android	
iOS 10.3 or later		Android 4.3 or later

Register your account by selecting sign up option in the App and follow in app instructions to complete the registration process. Add your pool to the app by choosing pool shape, bottom slope and Pool material. Add your new cleaner to the App under My Device by “+” button.

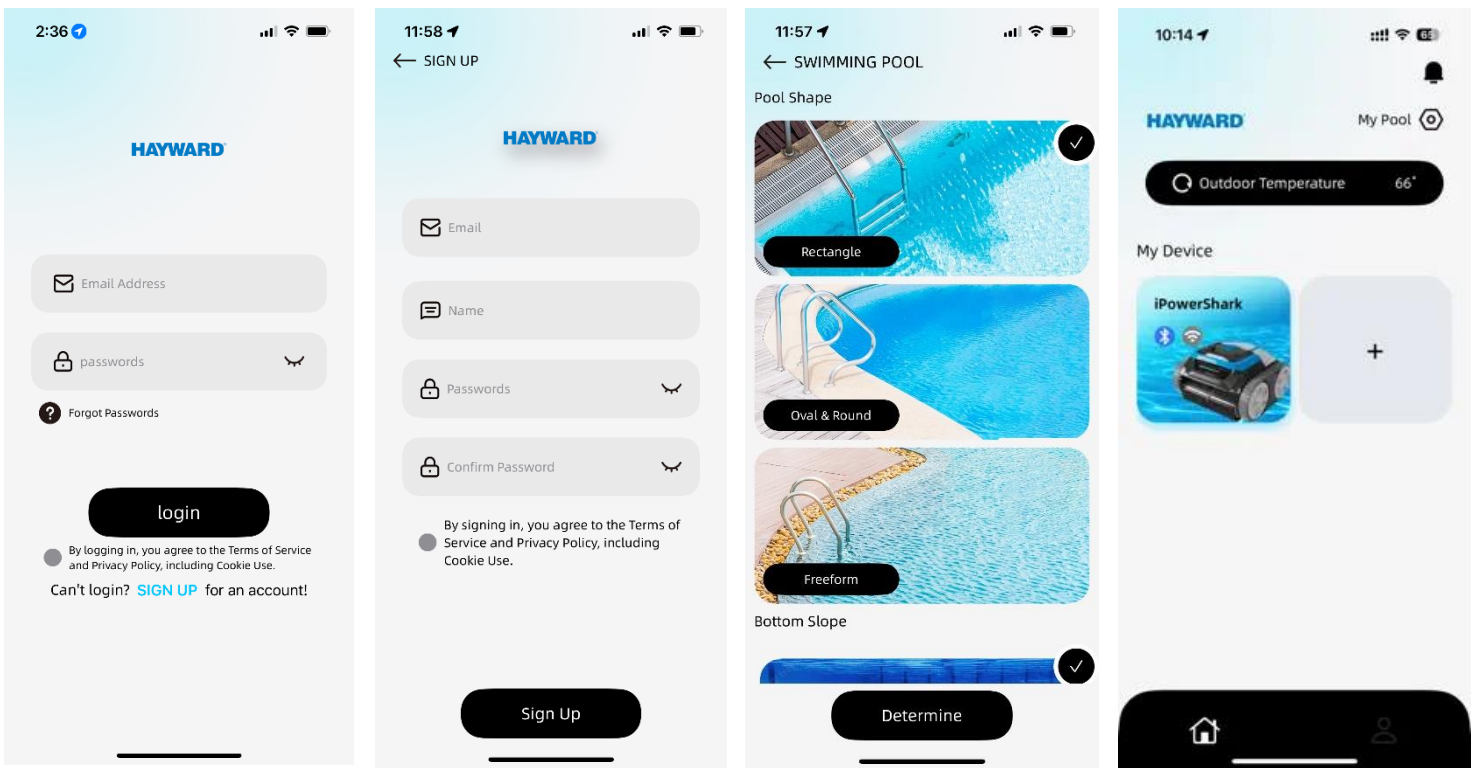

**Note:** Please ensure to enable Bluetooth in our mobile device during this operation. Keep your device out of water and within the range of Bluetooth. Your device will turn solid purple after a successful connection. After connecting to your App, you can choose a cleaning mode for your device from the 7 cleaning modes.

Mode	Cleaning Range
Standard Full-Pool	Wall+Floor+Waterline
Floor only	Floor
Wall only	Wall
Waterline	Waterline
Wall then floor (Combo)	Wall*1 + Floor*1
Eco floor	Floor cleaning only
Turbo floor	Powerful cleaning, floor cleaning only

**RUN YOUR NEW iPowerShark CLEANER**

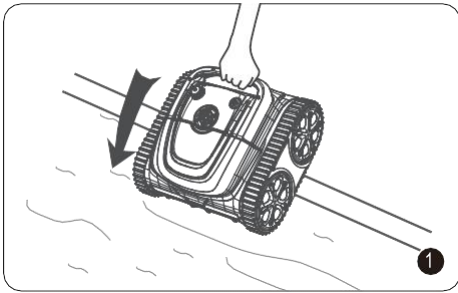

**TURN ON** the device and gently slide in to the water vertically by holding the handle

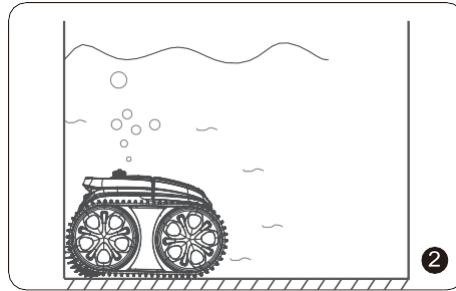

Let it sink down to the floor, and the cleaner will slowly discharge the air trapped inside. The blue indicator will flash for 30s and the cleaner will start the cleaning cycle selected on the App.

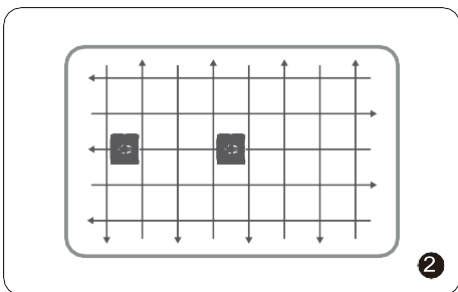

The cleaner will clean on walls, floor and waterline by default or as per the mode selected in your app.

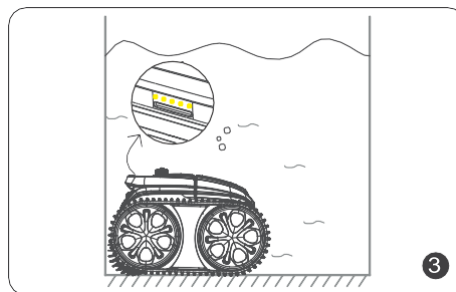

The cleaner will automatically move to stop by the edge of when finishing the cleaning cycle or battery is too low to continue operation or need charging.

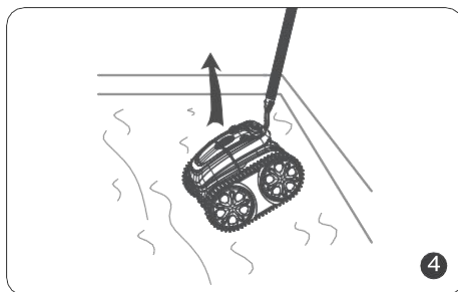

You could insert the included hook into a pool pole and use it to lift the cleaner out of pool.

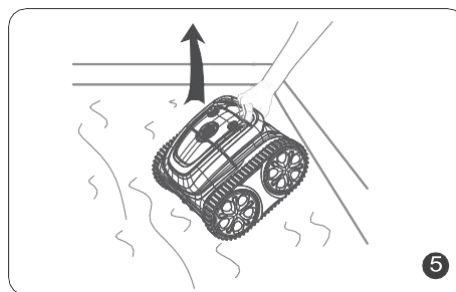

The cleaner should be taken out vertically to drain the water quickly.

**Note:** In order to get an ideal cleaning efficiency, it is important to have a water depth in the pool that is no less than 50cm from the top of the cleaner.



CLEANING THE BASKET

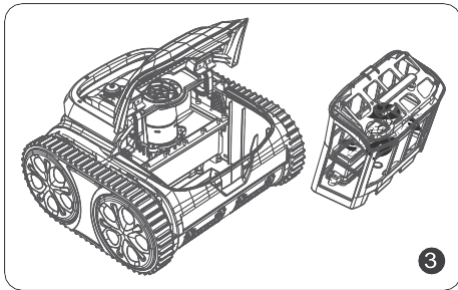

Take out the filter basket

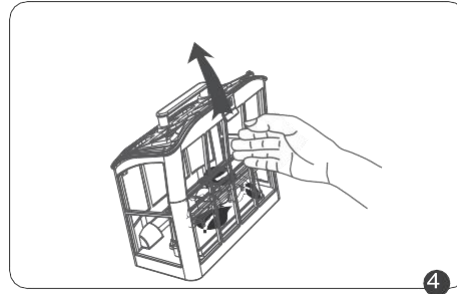

Release the lid of the basket by lifting the lock upwards.



Empty all debris and rinse it with clean water

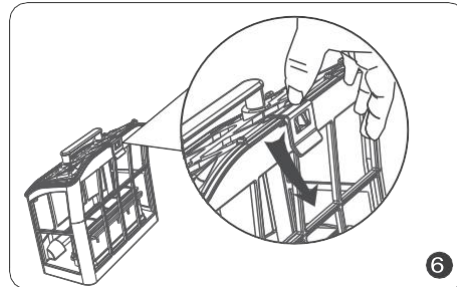

After rinsing, close the basket lid and close the lock.

## INSTALLATION OF FLOATING BLOCKS (OPTIONAL)

When it is difficult for the cleaner to climb the walls, it cannot clean the waterline, and it tilts seriously when climbing the walls, solve the problems according to the figure. If the machine climbs the walls normally, the following operations are not required. After removing the adhesive, two top floating blocks are attached to the machine. Carry out installation according to

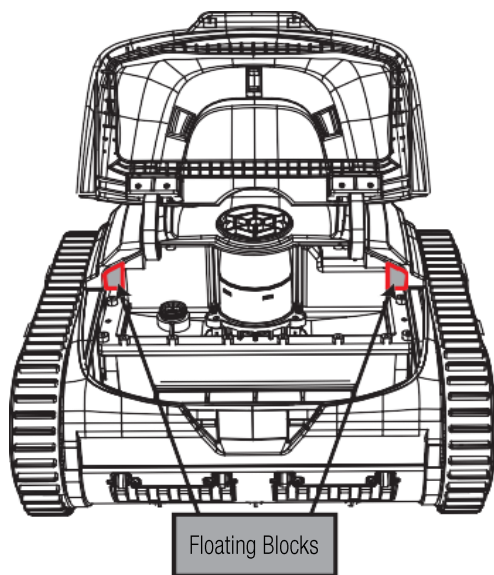

### Note:

- Before installation, ensure that there is no water in the bonding area.
- There is adhesive on the back of the top floating block. When installing the top floating block to the big cover, the edges of top floating block must be glued properly. After 24 hours, the machine can be put into the pool for work.

## LIMITED WARRANTY

### Warranty-Standard Conditions- Australia and New Zealand

To original purchaser of this equipment, Hayward Pool Products (Australia) warrants its products are free from defects in materials and workmanship for 3 years from the date of purchase, when used in single family residential applications.

The limited warranty excludes damages from freezing, negligence, improper installation, improper use or care or any acts of God. Parts that fail from a defect or become defective during the warranty period shall be repaired or replaced, at or option, within 90 days of the receipt of defective product, barring unforeseen delays, without charge.

Proof of purchase is required for warranty service. In the event if proof of purchase is not available, the product serial number will be the sole determination of the purchase date. A warranty claim can be raised by scanning following QR code or visiting us on our website [au.hayward.com](http://au.hayward.com)



Hayward shall not be responsible for cartage, removal, repair or installation labor or any other such costs incurred in obtaining warranty replacements or repair. The Hayward Pool Products (Australia) warranty does not apply to components manufactured by others.

The express limited warranty above constitutes the entire warranty of Hayward Pool Products with respect to its pool products and is in lieu of all other warranties expressed or implied, including warranties of merchantability or fitness for a particular purpose. In no event shall Hayward Pool Products be responsible for any consequential, special or incidental damages of any nature.

Some states do not allow a limitation on how long an implied warranty lasts, or the exclusion of incidental or consequential damages, so the above limitation may not apply to you. This warranty gives you specific legal rights, and you may also have other rights, which vary from state to state.

## MAINTENANCE

Adhering to these measures would help to maintain the performance of the cleaner to its utmost.

- Ensure the device is powered off after use.
- Dry out the cleaner and filter basket.
- Fully charge the battery
- Store the cleaner in a cool and ventilated place, away from direct sunlight, heat source and the ambient temperature between 5°C-45°C
- Charge the cleaner every three months to ensure optimal battery life.

NOTE: The device may not power up if the device being kept for too long without charging. Please go through the warranty claim process or contact us, do not attempt to disassemble.

## FAQ & TROUBLE SHOOTING

Q: What pool shapes and construction materials is the cleaner suitable for?

A: The machine can be applied to rectangle, oval, or irregular shapes of in-ground swimming pools. Applicable construction materials include PVC, granitite, tile and other materials.

Q: Will obstacles such as steps, shallow water areas, drains, slopes etc. in the swimming pool affect the running?

A: The machine can climb steps, drains, and shallow water areas. The above obstacles may influence its cleaning path, but will not affect the operation of the machine.

Q: Are the iPowerShark App able to control the device when cleaning under water?

A: Since the signal cannot be transferred under water, you need to preset the cleaning mode and cleaning path before put into the pool.

If you encounter following situations when using the cleaner, you can check the table below to solve them by yourself. Please contact after sales team, if you can not find a solution below.

## Troubleshooting guide

No	Issue	Details	Possible cause/s	Suggested solution
1	Device does not work	A solid red light	Impeller is stuck	Check the Impeller and clean
		A flashing red light	Motor protection	Restart
		A flashing red light	The device is not submerged in water, or the pool water is too shallow	Restart and submerge the device into the pool immediately. The depth of water should be more than 0.5m from device
		A breathing yellow light	Battery low	Fully charge the device and restart
2	Unable to charge	Charger light flashes	Poor contact or moisture in the charging port	Dry the charging port and Re-plug the charger
3	Do not climb walls		Slippery pool surface	Stick adhesive blocks inside (Contact after-sales team for instructions)
			Excessive dirty water	The device is suitable for maintain the cleanliness of pool. It is not recommended to use for seasonal cleaning
			Wrong cleaning modes set in the APP	Set wall cleaning mode
4	Abnormal wall climbing	Climbing slowly	Filter basket blocked	Clean the filter basket
		Sinking down away from wall or floating on the water	Air trapped inside Filter basket blocked	Stick adhesive blocks- Clean the filter basket
		Device front side lifting up from water	High friction against wall	Add more balancing weight (Contact after sales team)
5	Only clean part of Pool	Finishing the cycle without cleaning the full pool	Wrong cleaning mode	Connect to the App and re-choose a suitable cleaning mode
			Firmware not latest	Connect to the App and update the firmware
6	Front side up when on the floor		Filter basket blocked	Clean the filter basket
7	Do not clean as set cleaning path		Encounter obstacles	Clean the filter basket
	Stuck at water drains		Drain height is over 3cm	Help the machine move away from the obstacle
	Unable to connect to the App		Device power off	Restart
8	The App cannot be connected when the device is in the pool		Not available	Connect the device on the shore

PARTS LIST

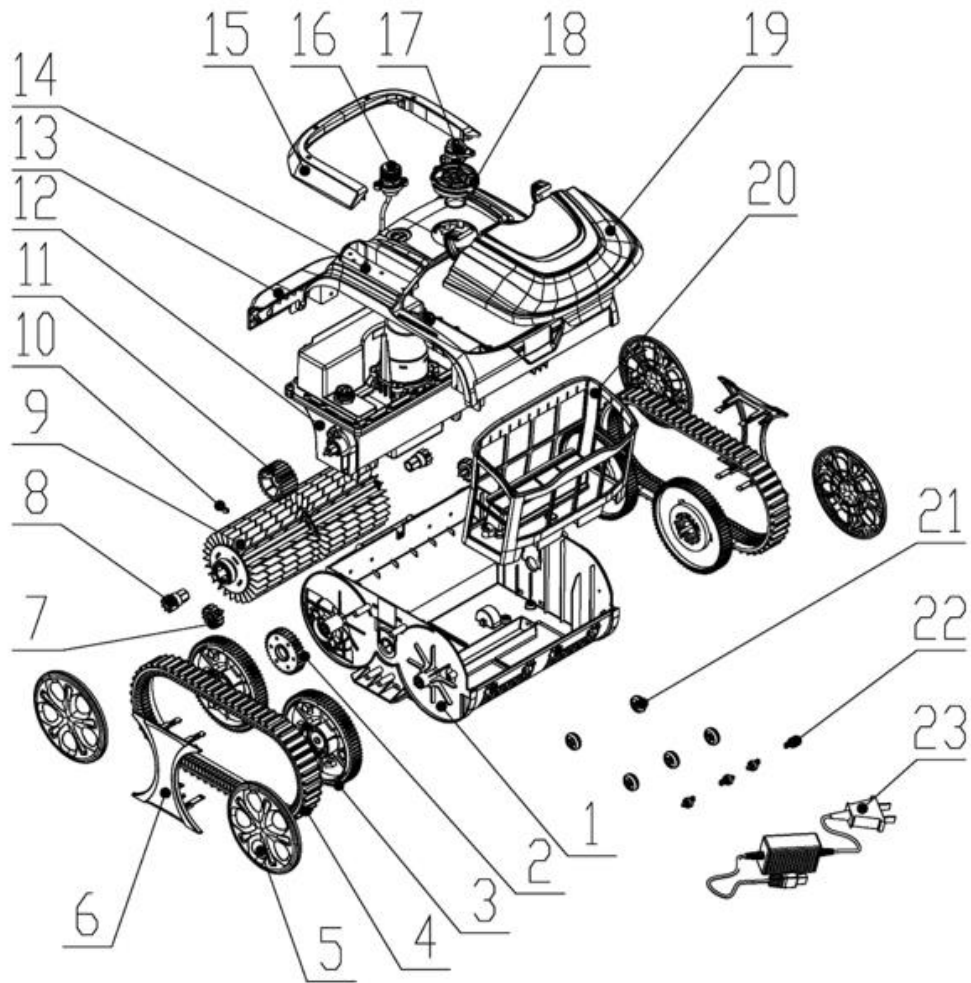

Item	Description	Part No	Qty
1	Base	RCHX450W1	1
2	Wheel gear	RCHX450W2	2
3	Wheel	RCHX450W3	4
4	Drive track belt	RCHX450W4	2
5	Wheel cover	RCHX450W5A	4
6	Side cover	RCHX450W6	2
7	Cylindrical gear	RCHX450W7	2
8	Roller gear	RCHX450W8	2
9	Brush roller	RCHX450W9	1
10	Nut	RCHX450W10	2
11	Driving gear	RCHX450W11	2
12	Motor box assembly	RCHX450W12A	1
13	Sensor seal box	RCHX450W13	1
14	Front cover	RCHX450W14A	1
15	Handle kit	RCHX450W15A	1
16	Charging plug	RCHX450W16	1
17	Power switch	RCHX450W17	1
18	Water outlet	RCHX450W18A	1

Use only Hayward® genuine replacement parts

19	Top cover	RCHX450W19A	1
20	Filter basket	RCHX450W20A	1
21	Bottom obstacle wheel	RCHX450W21	5
22	Front obstacle wheel	RCHX450W22	4
23	Charger	RCHX450W23A	1
24	Decorative cover	RCHX440W24A	1
25	Front face strip	RCHX440W25A	1





